



Exam Code: PMI-SP

Exam Name: PMI Scheduling Professional (PMI-SP)

Vendor: PMI

Version: DEMO

QUESTION NO: 1

Holly is the project manager of the NDS project and she is 85 percent complete with her project though she should be 95 percent complete. Her project has a BAC of \$9,850,400 and she has spent \$8,011,221 to date. What is Holly's schedule performance index for this project?

- A. 1.07
- B. 0.98
- C. 0.89
- D. Ten percent

Answer: C

QUESTION NO: 2

You are the project manager of the JKM Project for your organization. Your project is supposed to be 60 percent complete but you are only 45 percent complete. The project has an assigned budget of \$765,000 but you have already spent \$365,000 to reach this point in the project due to some errors and rework. Management is pressing you on when you'll complete the project and how much the project will likely cost based on the current performance. You need to tell management what the project's current cost performance index (CPI) is. What value should you report to management based on your project's performance?

- A. \$306,000
- B. .94
- C. \$344,250
- D. .75

Answer: B

QUESTION NO: 3

You are the project manager for the NHQ Project. Management has asked you to create a time estimate for this project although you have only just received the project charter. They would like some idea of how long the project will take based on the information in the project charter. While you are uncomfortable giving any type of estimate at this point, you work with your assigned project to create a quick time estimate. What type of estimate have you created for management?

- A. Analogous estimate
- B. Broad estimate
- C. Rough order of magnitude
- D. Expert judgment

Answer: C

QUESTION NO: 4

You are the project manager of the NHQ Project. You have created the project network diagram as shown in the figure:

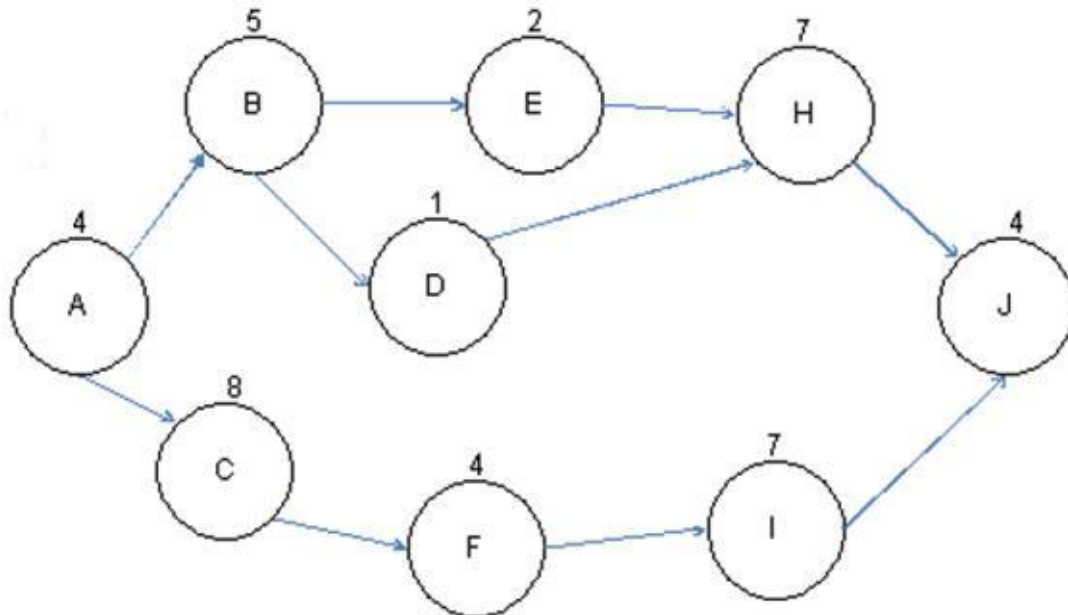

Based on the project network diagram, how much float is available for Activity H if Activity B is delayed by four days and Activity D is delayed by two days?

- A. One
- B. Five
- C. Four
- D. Zero

Answer: D

QUESTION NO: 5

You are the project manager for your organization. You are working with your project team to create activity duration estimates using the PERT method. What is the formula for PERT?

- A. $(O+ML+P)$
- B. $(O+(6M)+P)6$
- C. $(O+ML+P)/3$
- D. $(O+(4M)+P)/6$

Answer: D

QUESTION NO: 6

Gary is the project manager of the NHF project, which is a part of a program in his organization.

According to the PMBOK, how will Gary provide feedback to programs and portfolios?

- A. Status meetings
- B. Push communications
- C. Regular communications
- D. Status reports and change requests

Answer: D

QUESTION NO: 7

You are a project manager in a matrix environment and management is concerned about the utilization of the resources on your project team and when you'll release them. What project management plan will guide how and when project resources will be released from the project team?

- A. Project Human Resources Management Plan
- B. Project Staffing Management Plan
- C. Project Communications Management Plan
- D. Project Schedule Management Plan

Answer: B

QUESTION NO: 8

You are working as a project manager for BlueWell Inc. Which of the following tools and techniques of the Define Activity process will help you in identifying the typical schedule milestones?

- A. Expert Judgment
- B. Decomposition
- C. Rolling Wave Planning
- D. Templates

Answer: D

QUESTION NO: 9

Which of the following statements best describes an activity in a project?

- A. It is a defined set of functions a resource must complete for the project scope to be considered complete.
- B. It is the effort needed to complete a work package.
- C. It is the unit of resource utilization needed to complete a project deliverable.
- D. It is a listing of all project work that must be accomplished for the project scope to be considered complete.

Answer: B

QUESTION NO: 10

Fredrick works as a Project Manager for BlueWell Inc. A number of projects are running under his guidance. You, a team leader of a project, inform Fredrick about the performance indexes of your project. The schedule performance index (SPI) of your project is 1.325. What does this figure indicate?

- A. The schedule performance is better than expected.
- B. The schedule performance is right on target.
- C. The cost performance is better than expected.
- D. The schedule performance is below expectation.

Answer: A

QUESTION NO: 11

Which of the group creativity techniques enhances brainstorming with a voting process used to rank the most useful ideas for further brainstorming or prioritization?

- A. Idea/mind mapping
- B. Delphi technique
- C. Nominal group technique
- D. Affinity diagram

Answer: C

QUESTION NO: 12

Jack works as a project manager for the NHQ project. His project has a budget of \$2,208,456 and is scheduled to last for three years. His project is currently forty percent complete though it should be forty-five percent complete. In order to reach this point of the project, he has spent \$725,000. Management needs a performance report regarding the NHQ project. Management is concerned that this project will be over budget upon completion. Management would like to create a report telling them how much more the project will need to complete. What value should Jack tell the management?

- A. \$1,087,497.74
- B. \$755,000.56
- C. \$1,112,978.45
- D. \$790,988.76

Answer: A

QUESTION NO: 13

You are the project manager of the NHG. The following figure represents your project network diagram.

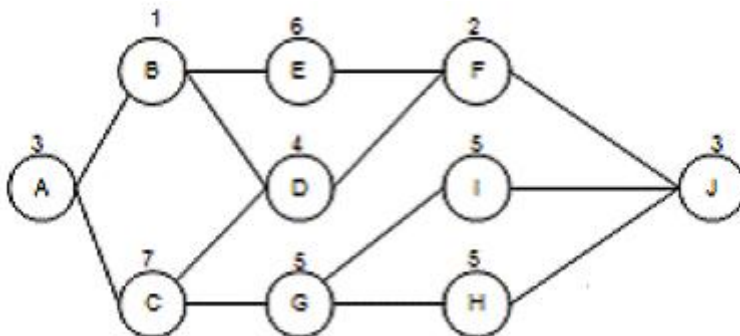

Management has asked that you add some features to the project scope. Through the change control system these changes are approved and they'll affect Activity I. The duration of Activity I, which is on the critical path, will decrease by three days. What affect does this have on the critical path?

- A. The critical path will now take 26 days.
- B. The critical path will now take 17 days.
- C. The critical path will now take 23 days.
- D. The critical path will now take 20 days.

Answer: C

QUESTION NO: 14

Marty is the project manager of the recently completed NHK Project. The project was deemed successful by the project customer and they have signed the formal acceptance documentation.

Marty has written the final project report, released the project team, and completed the lessons learned documentation. What else should Marty do in the closure of the NHK Project?

- A. Archive the project records.
- B. Summarize the project risks costs.
- C. Summarize the project variance.
- D. Close the project office.

Answer: A

QUESTION NO: 115

Diane is the project manager of the HGF Project. A risk that has been identified and analyzed in the project planning processes is now coming into fruition. What individual should respond to the risk with the preplanned risk response?

- A. Diane
- B. Project sponsor
- C. Risk owner
- D. Subject matter expert

Answer: C